

ALUCA

EASE YOUR WORK

INSTALLATION INSTRUCTIONS

ALUDB

EASE

YOUR WORK

Contents

1.	FOREWORD	2
2.	GENERAL INFORMATION	2
2.1.	MANUFACTURER INFORMATION	2
2.2.	GENERAL INFORMATION	2
2.3.	WARRANTY CONDITIONS	2
2.4.	INSTALLATION BY TWO PEOPLE.....	3
2.5.	ACCESSORIES.....	3
2.6.	PREVENTING CORROSION DAMAGE	3
2.7.	MOUNTING MATERIAL FOR BASE PLATE	3
2.8.	MOUNTING A BASE PLATE.....	3
2.9.	RELEASING THE 1,300 MM FULLY EXTENDABLE DRAWER SLIDE.....	3
2.10.	SELF-LOCKING SCREWS.....	3
2.11.	GOODS ACCEPTANCE.....	3
3.	TOOLS AND ADDITIONAL MATERIALS	5
4.	DELIVERY SCOPE.....	5
4.1.	MAIN COMPONENTS.....	5
4.2.	FURTHER COMPONENTS.....	5
4.3.	STANDARD INSTALLATION KIT FOR 940 TO 1240 SINGLE HOUSING	6
4.4.	STANDARD INSTALLATION KIT FOR 1340 SINGLE HOUSING	6
5.	PREPARATORY MEASURES/TASKS.....	6
5.1.	RELEASING DRAWERS WITH 900 MM SLIDES	6
5.2.	RELEASING DRAWERS WITH 1,300 MM SLIDES.....	7
5.3.	INSTALLING THE SIDE PANEL CLADDING.....	8
5.4.	MOUNTING THE ALUCA BASE PLATE.....	10
6.	INSTALLING THE ALUDB RACKING SYSTEM IN THE VEHICLE.....	12
6.1.	POSITIONING AND MOUNTING THE ALUDB RACKING SYSTEM	12
6.2.	POSITIONING OF THE INSTALLATION BRACKETS.....	14
6.2.1.	SINGLE HOUSING 940 TO 1240	14
6.2.2.	SINGLE HOUSING 1340.....	16
6.2.3.	DOUBLE HOUSING.....	18
7.	INSPECTION SCOPE FOLLOWING INSTALLATION	19
8.	TECHNICAL SPECIFICATIONS	20
8.1.	LOAD PROTECTION STICKERS.....	20
8.2.	PERMISSIBLE TIGHTENING TORQUE FOR SCREW CONNECTIONS.....	20
8.3.	USEFUL INNER DRAWER DIMENSIONS	21
	21
9.	CLEANING AND CARE.....	22

aluDB installation manual

1. Foreword

Congratulations on choosing a vehicle racking system from ALUCA. We are your partner for professional load securing. We would like to thank you for your trust in our safe and state-of-the-art product. Our products are generally delivered by a haulage company. NB: please observe our instructions on goods acceptance in section 2.11, as well as our T&Cs. These can be found online at www.aluca-world.com

This installation manual enables you to install your vehicle racking system in your vehicle in accordance with the generally accepted technical rules and standards.

2. General information

2.1. Manufacturer information

ALUCA GmbH
Westring 1
74538 Rosengarten
Germany

Tel.: +49 (0)791 950 400
Fax.: +49 (0)791 950 4020
Email: info@aluca.de

2.2. General information

ALUCA does not accept any warranty or guarantee for damage to the vehicle or personal injury resulting from the use of assembly material other than original ALUCA assembly material or from installation not in accordance with this installation manual.

We therefore recommend the installation of ALUCA racking systems by ALUCA or one of our trained and certified partners. This ensures that the vehicle racking system is installed in accordance with our current standards. Your vehicle racking system has been planned for your specific intended use, meaning that you may not require all mounting elements included in delivery.

Please note that professional installation is the only way to ensure a long service life of the system and a high level of safety. Therefore, you should read this installation manual carefully prior to installing the system.

The vehicle manufacturer's equipment manufacturer guidelines must be observed at all times.

2.3. Warranty conditions

Our warranty conditions can be found on our website at www.aluca-world.com/en/warranty-conditions/

aluDB installation manual

Should you wish to make a complaint, we will need your job number. This is located on our warranty seal, which can be found on the outer left side of the uppermost aluDB drawer.

2.4. Installation by two people

Due to its size and weight, an aluDB vehicle racking system should be installed by two installers trained by ALUCA.

2.5. Accessories

Installation manuals for accessories and/or custom parts will be provided separately with the products concerned.

2.6. Preventing corrosion damage

In order to prevent subsequent corrosion damage, all swarf must be vacuumed away following drilling.

2.7. Mounting material for base plate

The mounting material for the base plate, which is used to screw the plate to the vehicle's bodywork, is supplied with the base plate itself.

2.8. Mounting a base plate

When drilling into the bodywork, beware of possible framework components and electric, hydraulic or fuel lines that may run along the underside of the vehicle.

2.9. Releasing the 1,300 mm fully extendable drawer slide

In order to ensure safe use of the 1,300 mm fully extendable drawer slide, the drawer lock features a slightly heavier release mechanism.

2.10. Self-locking screws

The inner rails of our fully extendable slides are secured using self-locking screws. These cannot be reused following disassembly. Should you disassemble the inner rails of the fully extendable slides due to the installation situation, you will need to use new self-locking screws.

2.11. Goods acceptance

Please check that the freight documents are complete. Does the number of packaging items (e.g. disposable pallet, cardboard box) match the details on the paperwork?

Carry out a visual inspection of the packaging items for visible damage to the outer packaging in the presence of the carrier. You must fully unpack the goods and check that they are complete within three days.

If you notice any defects during the incoming goods inspection, these must be reported immediately using the *Submit complaint* form to reklamation@aluca.de.

aluDB installation manual

Obvious/recognisable transport damage

Recognisable transport damage is apparent on delivery. Recognisable transport damage also includes any damage that only becomes apparent when the recipient opens part of the undamaged packaging in the presence of the carrier and thus discovers the concealed transport damage. This must be immediately documented by hand on the freight paperwork.

If the delivery driver does not permit you to accept the goods with a note of damage (if, for example, they insist on a signature without a note), please refuse acceptance of the goods and notify us immediately via reklamation@aluca.de.

If the delivery driver only offers the option of noting damage on a mobile electronic device, firmly insist on an additional handwritten damage note on the waybill/delivery note.

Never confirm 'Concealed damage' or 'Defective packaging', as damage declared in this way will not be recognised by the haulage company's insurer(s).

If it is apparent that the equipment is damaged beyond repair, please refuse acceptance of the goods and notify us via reklamationen@aluca.de.

Concealed transport damage

In the event that concealed transport damage is identified within three working days, a detailed written report must be sent immediately to ALUCA. To do so, please email the delivery note/waybill, along with photos of the damaged packaging and goods. Please use the *Submit complaint* form to tell us which parts are damaged. Our representative in the Complaints Management department will arrange the next steps with you.

After the period of three working days has elapsed, we will no longer recognise any subsequent complaints on the basis of recognisable or concealed transport damage. As such, any subsequent deliveries required will be charged to the recipient. We invoke Sect. 425/438 of the German Commercial Code (HGB) in conjunction with Sect. 25/28 of the German Freight Forwarders' Standard Terms and Conditions (ADSp).

3. Tools and additional materials

To install an aluDB vehicle racking system, you will require the following tools and materials:

- 10 mm open-ended ring wrench
- Ratchet with a 10 mm socket and 13 mm socket with extension
- Power drill
- Steel drill bits – Ø of 6.5 mm, 9.0 mm and 11.0 mm
- Wood drill bits – Ø of 3.0 mm, 7.0 mm and 11.0 mm
- Hammer
- Plastic/rubber hammer
- Torque wrench
- Centre punch
- Gloves for removing and installing the aluDB drawers

4. Delivery scope

4.1. Main components

Depending on the order, your aluDB vehicle racking system comes with the following main components:

- Depending on the configuration, an aluDB housing
- Depending on the configuration, aluDB drawer(s) incl. fully extendable slides
- Depending on the configuration, the standard installation kit with the various installation brackets

4.2. Further components

Depending on your order, additional components may also be included with delivery:

- Partition walls and dividers
- Inset boxes
- Anti-slip mats
- Electrical accessories
- Cases and boxes
- Elements or products for in-vehicle installation
- Cover plate with installation kit
- Base plate
- Side panel cladding

aluDB installation manual

4.3. Standard installation kit for 940 to 1240 single housing

Installation bracket 1

- 2x heavy-load cage nut
- 2x pan-head screw with flange (M8 x 12)
- 2x ALUCA installation bracket 1
- 2x drive-in nut M8
- 2x ring washer M8
- 2x screw M8

Installation bracket 2

- 4x heavy-load cage nut
- 4x pan-head screw with flange (M8 x 12)
- 2x ALUCA installation bracket 2
- 4x drive-in nut M8
- 4x ring washer M8
- 4x screw M8

Installation bracket 3

- 2x heavy-load cage nut
- 2x pan-head screw with flange (M8 x 12)
- 2x ALUCA installation bracket 3
- 2x drive-in nut M8
- 2x ring washer M8
- 2x screw M8

4.4. Standard installation kit for 1340 single housing

Installation bracket 1

- 2x heavy-load cage nut
- 2x pan-head screw with flange (M8 x 12)
- 2x ALUCA installation bracket 1
- 2x drive-in nut M8
- 2x ring washer M8
- 2x screw M8

Installation bracket 2

- 8x heavy-load cage nut
- 8x pan-head screw with flange (M8 x 12)
- 4x ALUCA installation bracket 2
- 8x drive-in nut M8
- 8x ring washer M8
- 8x screw M8

Installation bracket 3

- 2x heavy-load cage nut
- 2x pan-head screw with flange (M8 x 12)
- 2x ALUCA installation bracket 3
- 2x drive-in nut M8
- 2x ring washer M8
- 2x screw M8

Check your order by comparing the components delivered against the delivery note.

5. Preparatory measures/tasks

Our aluDB vehicle racking system comes pre-assembled. To enable straightforward installation in the vehicle, all drawers must be disassembled.

- Prepare the vehicle for installation.
- If applicable, remove the rubber floor.
- Remove any boxes and loose parts.
- Open the drawer slide all the way to the stopper.
- Lay the base plate in the vehicle so that it fits.

5.1. Releasing drawers with 900 mm slides

To prevent grease stains on the aluDB vehicle racking system, we recommend that you wear gloves when removing the drawers.

- There are two drawer locks, one on the right of the slide and one on the left.
- In order to release the drawer, the locks are activated simultaneously and in opposite directions.



Fig. 01

aluDB installation manual

- On one side (Fig. 01 and Fig. 02), the lock is pressed down.
- On the other side (Fig. 03 and Fig. 04), the lock is pushed up.
- The locks will release.
- Pull the drawer towards you to remove.

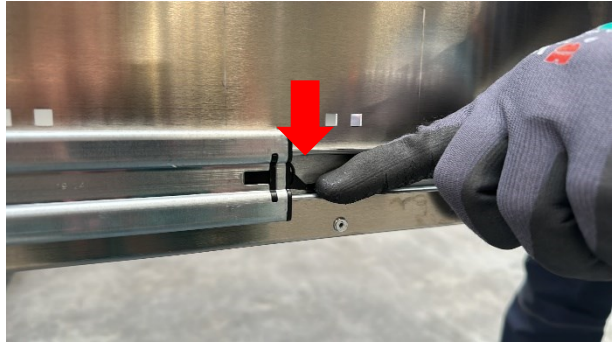

Fig. 02



Fig. 03

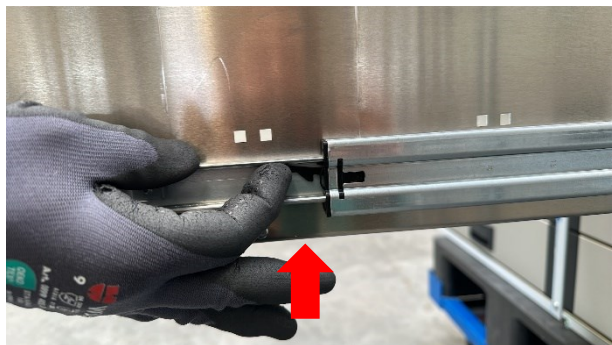

Fig. 04

5.2. Releasing drawers with 1,300 mm slides

To prevent grease stains on the aluDB vehicle racking system, we recommend that you wear gloves when removing the drawers.

- There are two drawer locks, one on the right of the slide and one on the left (Fig. 05)
- In order to release the drawer, the locks on both sides must be simultaneously pressed inwards (Fig. 06).
- The locks will release.
- Pull the drawer towards you to remove.



Fig. 05

aluDB installation manual

Should the release mechanism be slightly heavier, use a screwdriver on both sides and press the locks inwards (Fig. 07 and Fig. 08).



Fig. 06



Fig. 07

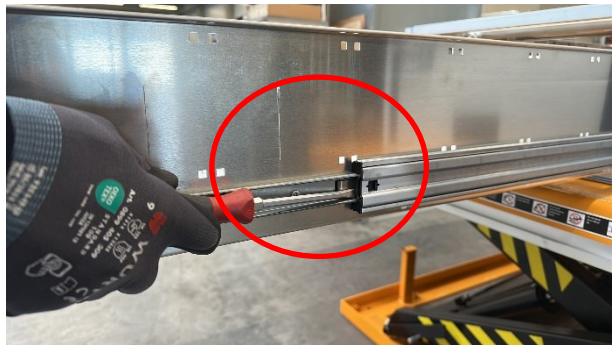
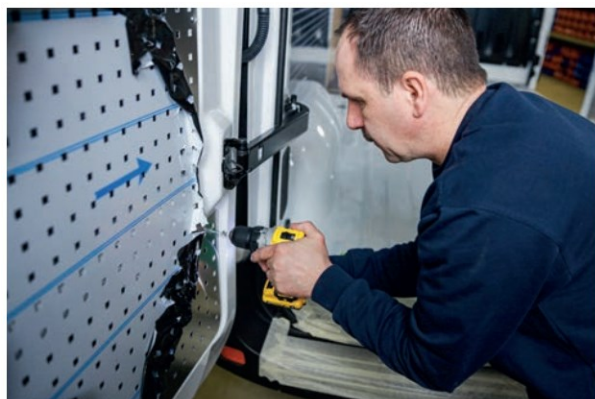

Fig. 08

5.3. Installing the side panel cladding

The side panel cladding has been made to measure for your vehicle. We recommend that you affix felt strips or attach silicone to the reverse of the side panel cladding to prevent occasional noises due to vibration. Silicone and felt strips are not supplied with the side panel cladding. We recommend silica-free silicone. The cladding is attached to the vehicle's beams using self-tapping screws for sheet metal. The self-tapping screws are not supplied. Optionally, the side panel cladding can be mounted using rivets. The rivets are not supplied.



aluDB installation manual

All attachments must be tightened with the permissible torque and clearly marked. For more information, please see section 8: 'Technical specifications'.

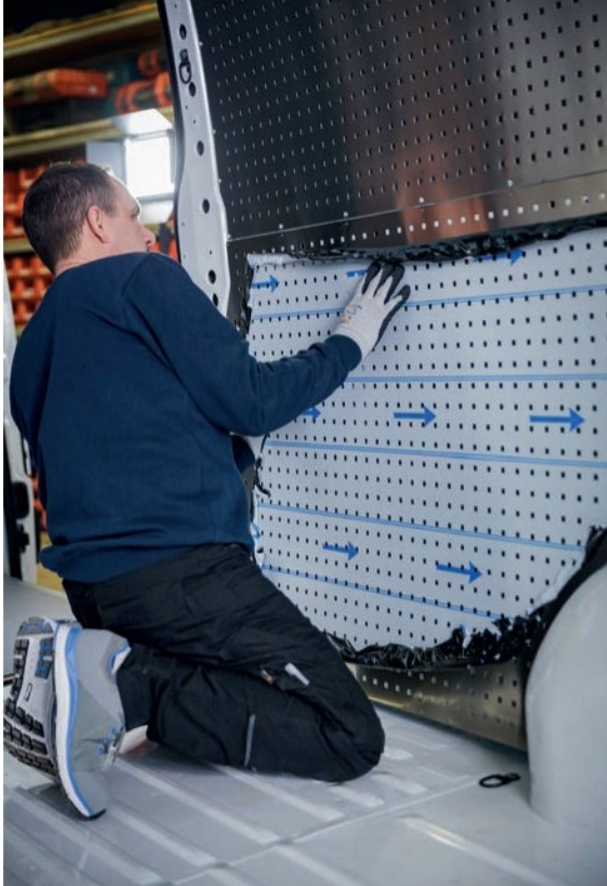

aluDB installation manual

5.4. Mounting the ALUCA base plate

ALUCA base plates are mounted using the original lashing points. Please note that the cover and lid should be used for all common vehicle types.

Due to the vehicle construction, the cover may not lie flush on the vehicle's bodywork. In these cases, the cavities must be filled with bodywork washers (not included) in order to enable force to be transmitted in the event of loads on the lashing point.

The base plate may additionally be affixed or secured using self-tapping bodywork screws. The adhesive is not supplied with the base plate. We recommend windscreen adhesive.

Please ensure that there is a gap of at least 4 mm between the plate and the bodywork.

We recommend that you partially line the underside of the plate with anti-slip mats to reduce impact noise. This minimises footfall noise.



Base plates without lashing eye attachment

Mark the attachment points of the drill holes via which the base plate and bodywork will be screwed together.



Base plates with lashing eye attachment

Attach the base plate using the supplied covers and lids (included with the base plate).

Cover



Lid



aluDB installation manual



Once the base plate has been inserted, mark the second drill hole.

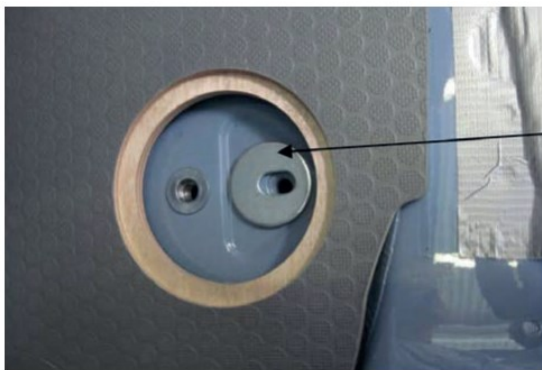

Drill the holes with a step drill. Any uneven sections should be levelled using bodywork washers (20 mm diameter). These are not included.



Reattach the lashing points with original screws. It may be necessary to insert the lid into the cover using a plastic hammer. Do so carefully in order to avoid damaging the plastic. All attachments must be tightened with the permissible torque and clearly marked (see section 8: 'Technical specifications').

aluDB installation manual

6. Installing the aluDB racking system in the vehicle

6.1. Positioning and mounting the aluDB racking system

Position the housing on the base plate

Place the housing inside the vehicle and align it on the base plate.

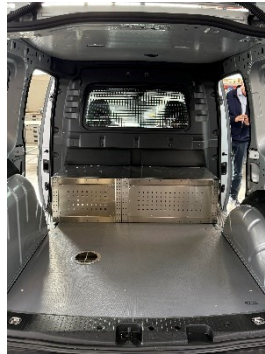

Mark the attachment points

Mark the attachment points at which the housing and base plate will be screwed together. Remove the housing and base plate from the vehicle.

The base plate may remain inside the vehicle if you also intend to screw aluDB through the bodywork.

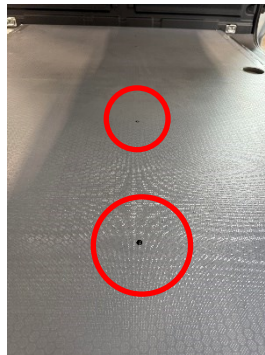

Drill through the base plate

Drill through the base plate from above with a diameter of 11 mm. The M8 drive-in nuts are inserted into the drill holes from below.



Re-insert the base plate into the vehicle (smooth side facing downwards). Align and screw down the base plate.

Return the housing into position. The housing is attached using the installation brackets supplied. To this end, the brackets are screwed onto both the housing and the base plate. The images in section 6.2 illustrate the process of attaching the installation brackets to the housing.

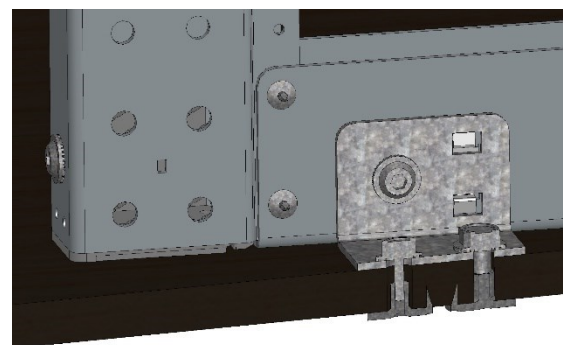

Example: on installation bracket 1

Depending on the housing situation, you will receive the standard installation kits specified in aluPlan. The positioning of the installation brackets is described in section 6.2.

aluDB installation manual

All attachments must be tightened with the permissible torque and clearly marked (see section 8: 'Technical specifications').

Attach the cover plate to the housing

Mark the attachment points for the cover plate on the housing and insert the centre punches into the designated holes with a 6 mm diameter. Place the cover plate over the housing and centre-punch it into position.



Remove cover plate, drill and screw

Remove the cover plate from the vehicle and take out the centre punches. To prevent any loss of the grey coating on the cover side, start by drilling the marked points on the cover side from the underside (brown side) with a 3 mm-diameter drill. In a second step, drill from the cover side to the underside (brown side) using a 7 mm-diameter drill. The drill holes must then be countersunk. Then screw the cover plate onto the housing (countersunk screws). Once you have completed your installation work, vacuum away all swarf in order to prevent subsequent corrosion.

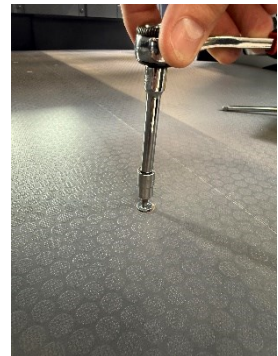
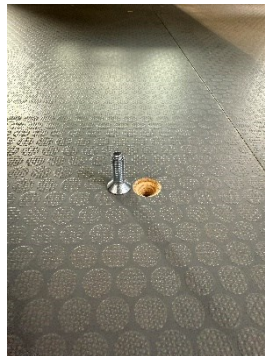

Insert drawers

Re-insert the drawers into the housing using the rails and fix them into position. (see disassembly)

aluDB installation manual

6.2. Positioning of the installation brackets

6.2.1. Single housing 940 to 1240

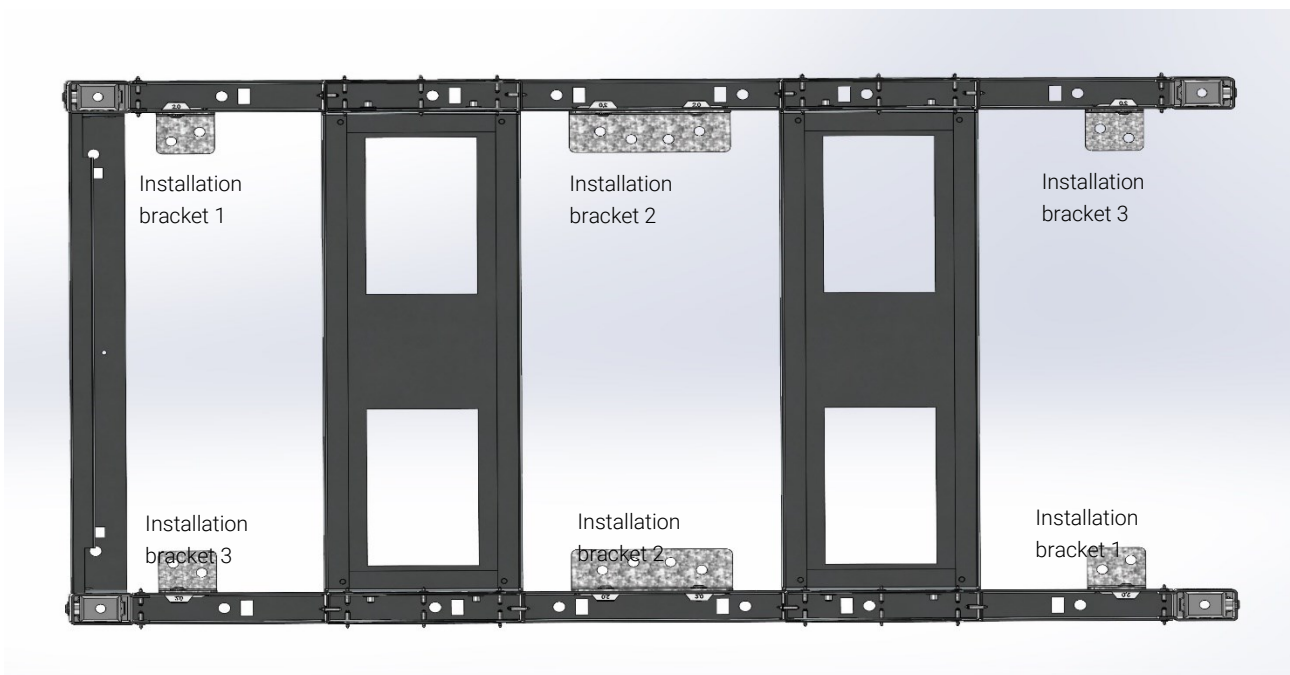
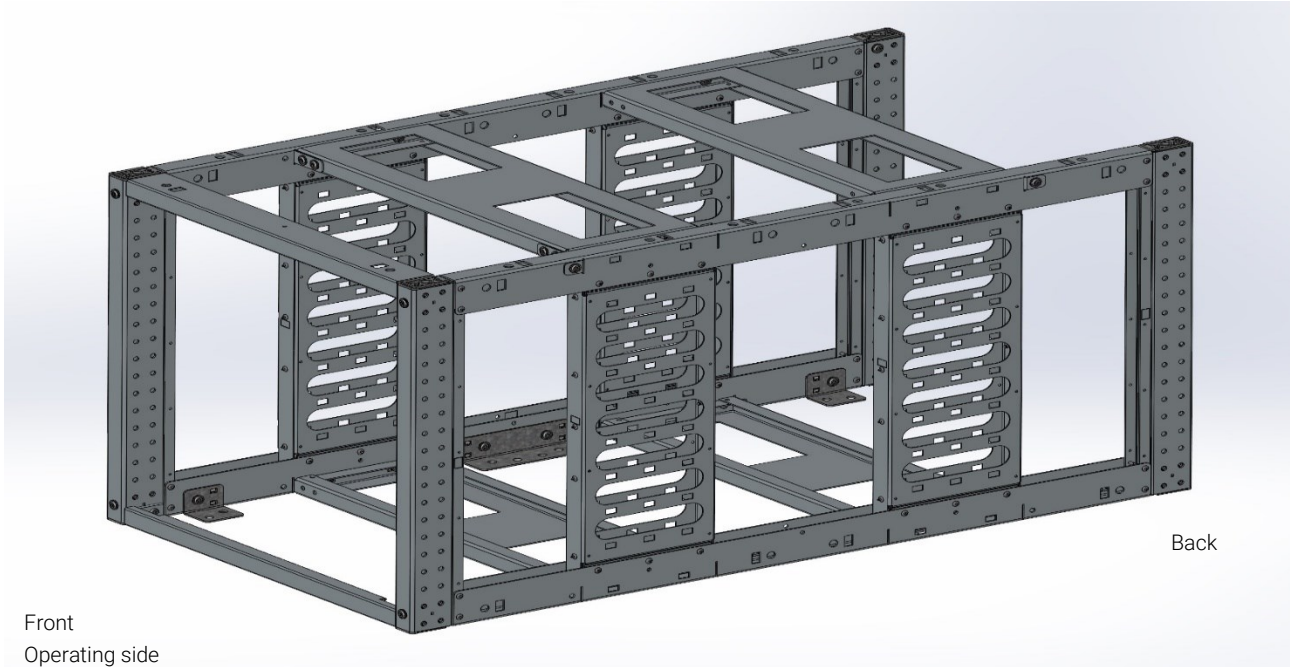

aluDB installation manual

Attaching the installation brackets at the front and back (installation brackets 1 and 3)

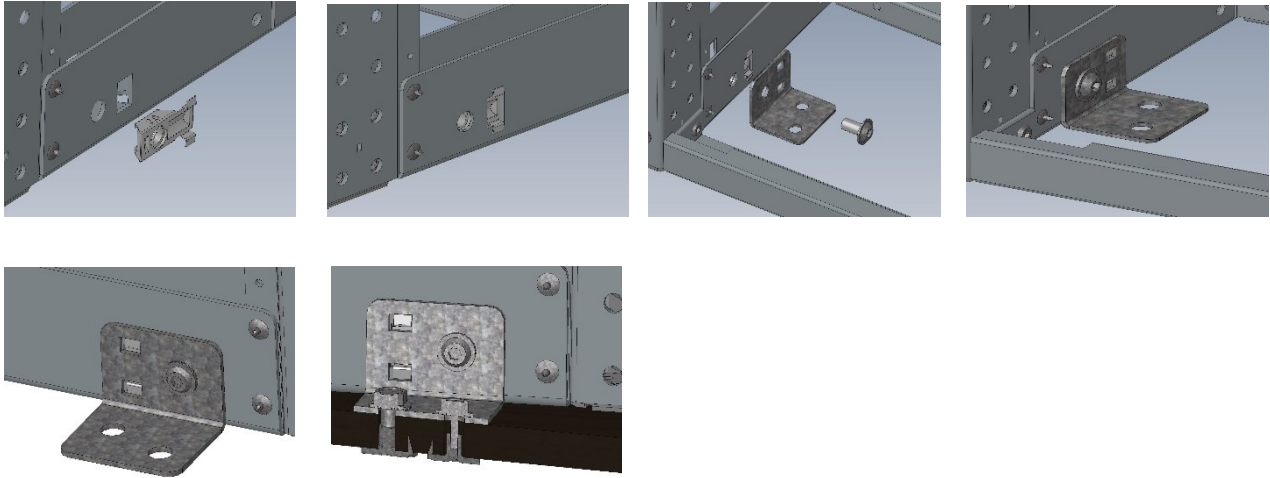

Attaching the installation bracket in the middle (installation bracket 2)

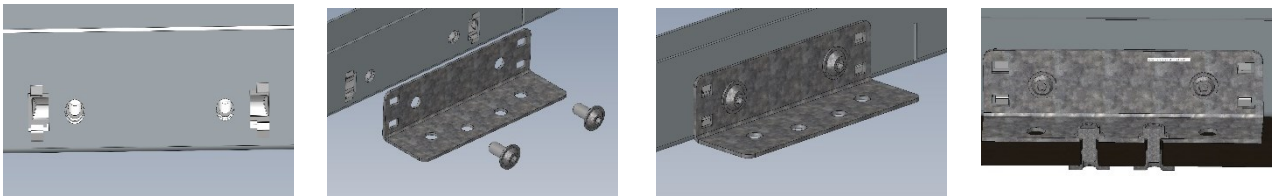

Cross-section showing the installation bracket with cage nut and screw

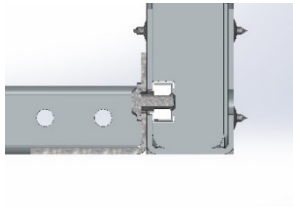

aluDB installation manual

6.2.2. Single housing 1340

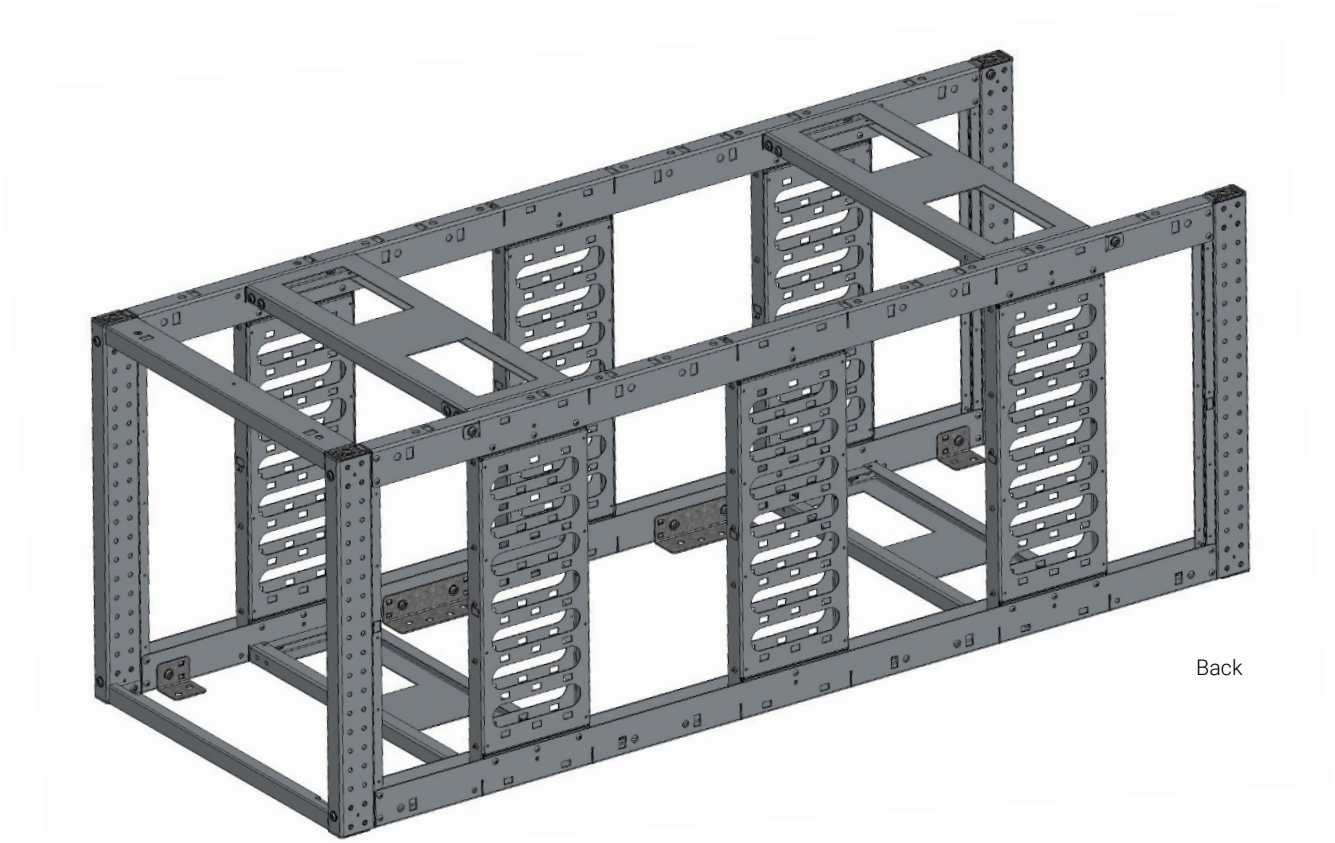

Back

Front
Operating side

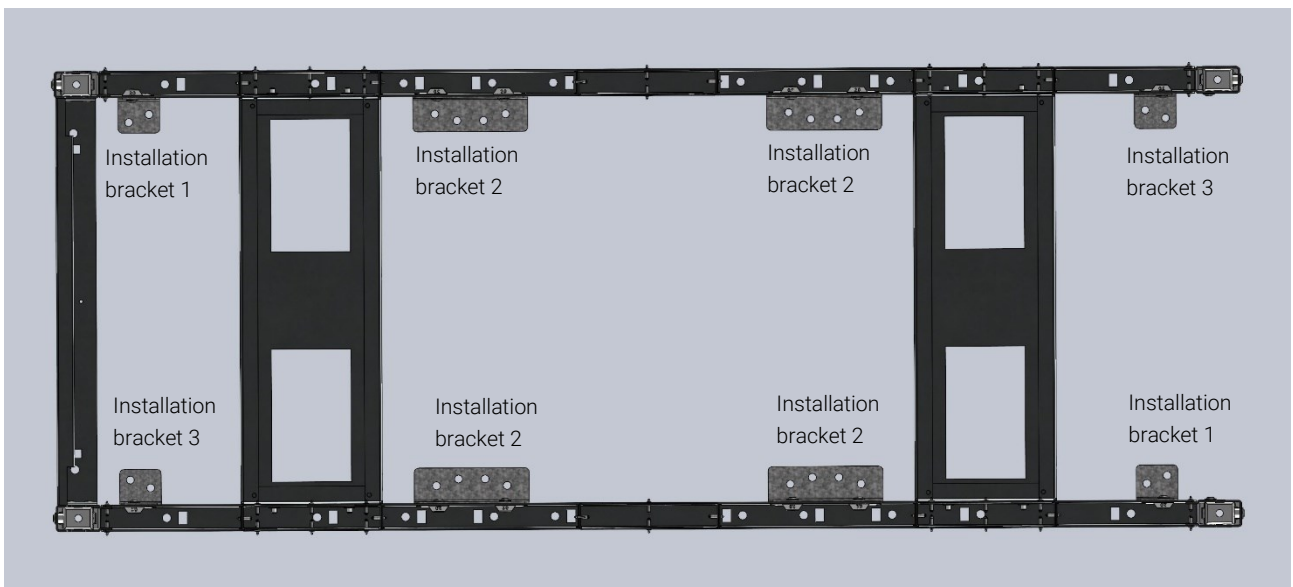

aluDB installation manual

Attaching the installation brackets at the front and back (installation brackets 1 and 3)

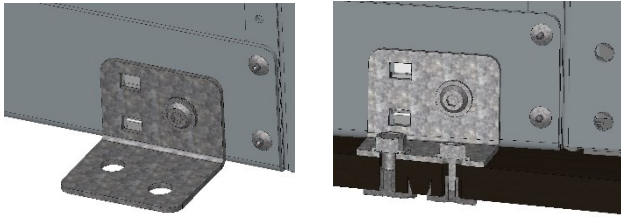
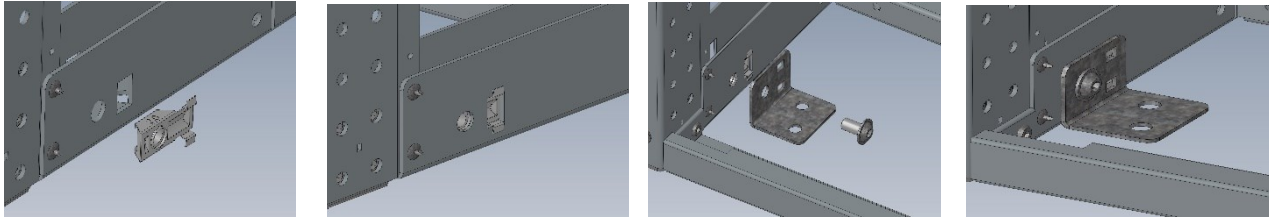

Attaching the installation bracket in the middle (installation bracket 2)

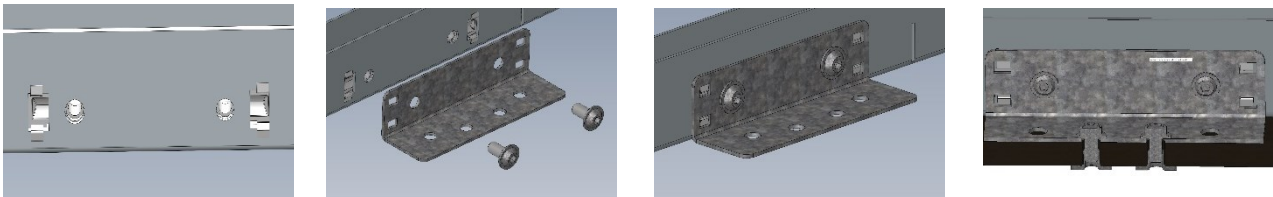

Cross-section showing the installation bracket with cage nut and screw

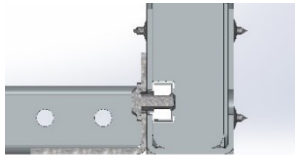

aluDB installation manual

6.2.3. Double housing

Please note that the central supporting frame must be fixed on both sides using all installation brackets. In the images below, this is illustrated using the example of the double housing 1340.

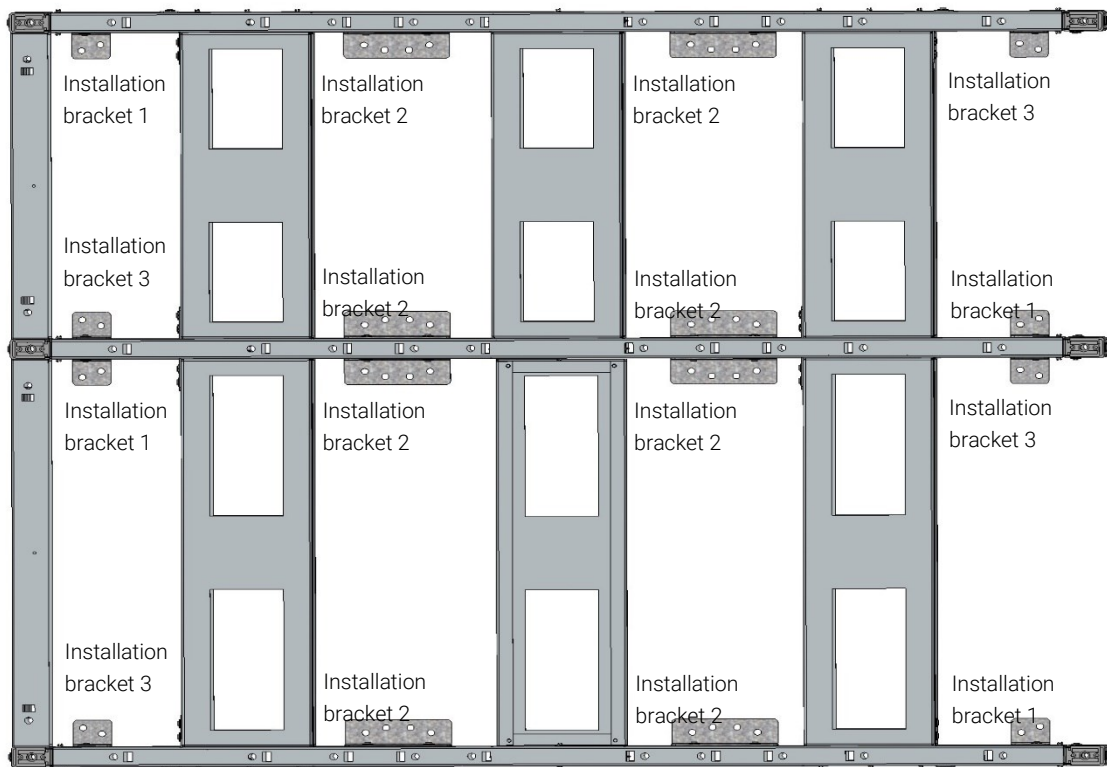
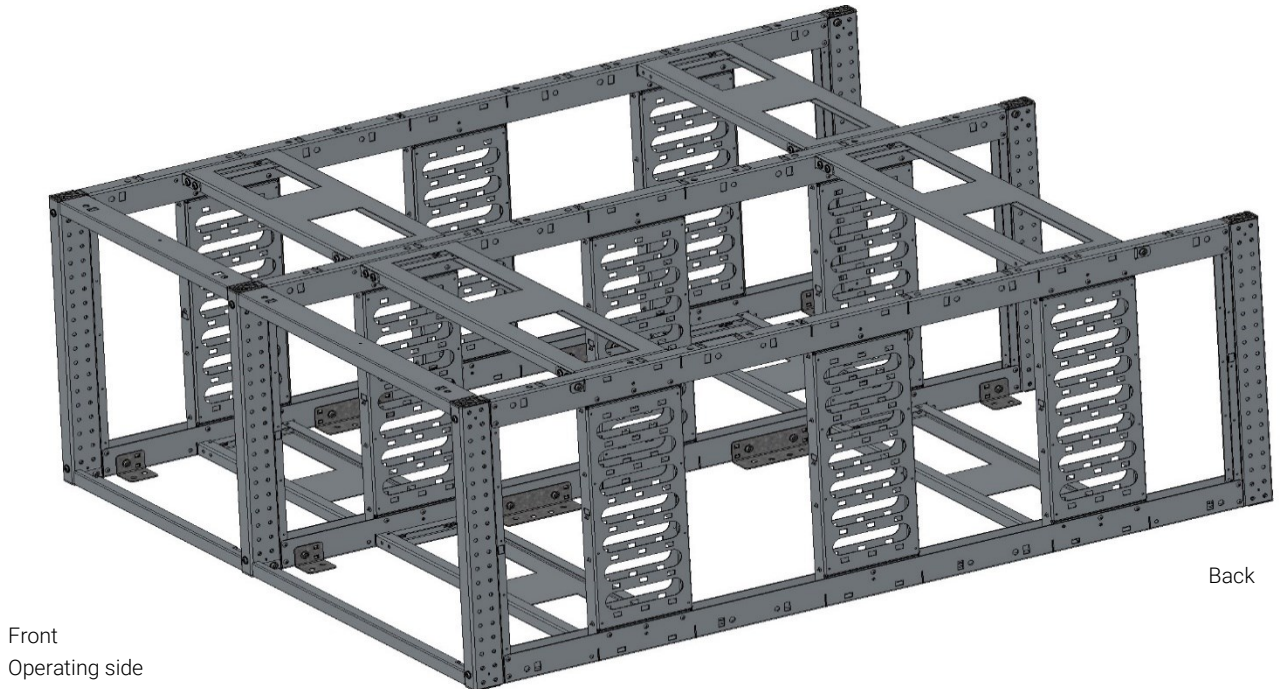

aluDB installation manual

7. Inspection scope following installation

We provide you with a checklist, allowing you to inspect the installation of the aluDB vehicle racking system and its supplied accessories.

Relevant	Not relevant	Inspected			
<input type="checkbox"/>	<input type="checkbox"/>	<input type="checkbox"/>	Racking system is installed as per items list/delivery note and drawing(s), dimensions checked		
<input type="checkbox"/>	<input type="checkbox"/>	<input type="checkbox"/>	All functional components (drawers, flaps, etc.) inspected following installation		
<input type="checkbox"/>	<input type="checkbox"/>	<input type="checkbox"/>	Accessories installed as per drawing(s)		
<input type="checkbox"/>	<input type="checkbox"/>	<input type="checkbox"/>	ALUCA load protection stickers affixed		
<input type="checkbox"/>	<input type="checkbox"/>	<input type="checkbox"/>	All screw connections are at right angles to the contact surface		
<input type="checkbox"/>	<input type="checkbox"/>	<input type="checkbox"/>	Further use of screws avoided		
<input type="checkbox"/>	<input type="checkbox"/>	<input type="checkbox"/>	All attachments (wall, floor) have been tightened with permissible torque – as per table in the installation manual		
<input type="checkbox"/>	<input type="checkbox"/>	<input type="checkbox"/>	All attachments (wall, floor) are clearly marked following installation		
<input type="checkbox"/>	<input type="checkbox"/>	<input type="checkbox"/>	Electrical connections in accordance with VDE guidelines, no cables running over sharp edges		
<input type="checkbox"/>	<input type="checkbox"/>	<input type="checkbox"/>	RCCB – activate test	OK	<input type="checkbox"/>
<input type="checkbox"/>	<input type="checkbox"/>	<input type="checkbox"/>	Insulation monitoring device – activate test	OK	<input type="checkbox"/>
<input type="checkbox"/>	<input type="checkbox"/>	<input type="checkbox"/>	Functionality of electrical accessories (inverter, LED lighting, etc.)		
<input type="checkbox"/>	<input type="checkbox"/>	<input type="checkbox"/>	Floor sealing (bodywork) complete		
<input type="checkbox"/>	<input type="checkbox"/>	<input type="checkbox"/>	Floor and roof vents installed and inspected for tightness		
<input type="checkbox"/>	<input type="checkbox"/>	<input type="checkbox"/>	Attachment and functionality of further additions/installations		
<input type="checkbox"/>	<input type="checkbox"/>	<input type="checkbox"/>	Roof rack, ladder lift, warning beacon, warning light(s), satnav device, hands-free kit, charging cradle		
<input type="checkbox"/>	<input type="checkbox"/>	<input type="checkbox"/>	Vehicle interior cleaned and swarf removed from the floor and supporting frame		
<input type="checkbox"/>	<input type="checkbox"/>	<input type="checkbox"/>	Seats and seat belts attached and/or replaced with tightening torque in accordance with equipment manufacturer guidelines		
<input type="checkbox"/>	<input type="checkbox"/>	<input type="checkbox"/>	Other accessories (loose parts) included as per delivery note		
<input type="checkbox"/>	<input type="checkbox"/>	<input type="checkbox"/>	Battery voltage measurement following installation (on vehicle return)		
<input type="checkbox"/>	<input type="checkbox"/>	<input type="checkbox"/>	Battery voltage OK and/or battery charged (if voltage is below the figure specified by the manufacturer)		
<input type="checkbox"/>	<input type="checkbox"/>	<input type="checkbox"/>	Wheel nuts/bolts complete and tightened using the designated torque wrench Re-tighten every 50 km – necessary if wheels have come loose	Testing equipment / serial no.	
<input type="checkbox"/>	<input type="checkbox"/>	<input type="checkbox"/>	Tyre pressure tested and adjusted on all wheels/vehicles (if tyre pressure is below the figure specified by the manufacturer)	Target*	Actual

Remarks:

Mileage on handover:

8. Technical specifications

8.1. Load protection stickers

Our load stickers are enclosed with all pre-assembled racking systems. Affix these in a prominent position on the racking system or vehicle. These stickers indicate the loads that may be applied on our products and on lashing points retrofitted by us.

8.2. Permissible tightening torque for screw connections

Thread size	Tightening torque for regulation thread Torque in Nm		
Strength class	8.8	10.9	12.9
M5	6.03	8.48	10.18
M6	10.25	14.41	17.29
M8	24.93	35.06	42.07

All attachment points on the vehicle racking system should be inspected at regular intervals (approx. every 5,000 km) This applies both to floor/wall connections and lashing point connections.

- Check the permissible payload of the vehicle prior to use.
- Bear in mind that the vehicle racking system counts towards the payload.
- Observe the axle loads specified by the manufacturer.
- Avoid one-sided weight distribution within the vehicle.

Installations in passenger cars and vans that are solidly attached within the cargo area are classed as cargo. There are no road traffic provisions for cargo that require approval by recognised experts or a note in the vehicle registration documents. With the possible exception of official bodies.

8.3. Useful inner drawer dimensions

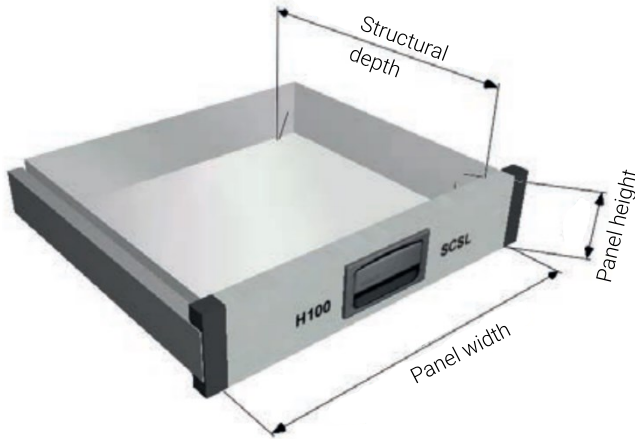

	Panel width*	Structural depth*	Panel height*
SystemALUCA	Less 40 mm	Less 45 mm	Less 14 mm
dimension2	Less 40 mm	Less 45 mm	Less 14 mm / 28 mm if height is 450 mm
aluDB up to 150 mm in height (one-piece)	Less 40 mm	Less 49 mm	Less 17 mm
aluDB up to 200 mm in height (multiple pieces)	Less 40 mm	Less 51 mm	Less 32 mm

* The measurements used by ALUCA are system measurements and therefore represent nominal dimensions. Actual dimensions may vary.

If making any repairs, only use original ALUCA spare parts.

ALUCA GmbH recommends separating the passenger area from the cargo area using partition walls or separator grids approved by the vehicle manufacturer. If viewing windows are built into the partition walls, a clearance certificate must be provided by the vehicle manufacturer.

ALUCA always recommends fitting any such windows with a protective grid in order to increase passive safety in the passenger area.

Any loose parts in the cargo area must be secured by means of suitable and approved load securing equipment.

ALUCA GmbH recommends informing all personnel who use a vehicle racking system of the applicable load securing regulations and on the optimum use of the product by means of suitable and documented training. It must always be ensured, for example, that heavy cargo is transported in the lower section of the vehicle racking system. Lightweight cargo, on the other hand, must always be stowed in the upper section of the racking system.

9. Cleaning and care

ALUCA vehicle racking systems are made from high-quality aluminium. This material does not require a finish. Therefore, cleaning is extremely easy and can be performed within the vehicle. Use a high-quality cleaning product for the care of metal surfaces.

Never use steel wool, steel brushes or similar products that form rust due to abrasion of the cleaning equipment used. After each clean, all surfaces should be treated with a high-quality product for the care of metal surfaces.